

Schröder

ZYLINDO

Installation instructions

ENG	INSTALLATION INSTRUCTIONS	ITA	ISTRUZIONI DI INSTALLAZIONE	NLD	INSTALLATIE INSTRUCTIES	DAN	INSTALLATIONSVEJLEDNING	HUN	TELEPÍTÉSI ÚTMUTATÓ
DEU	INSTALLATIONSANLEITUNG	POL	INSTRUKCJE MONTAŻU	RUS	Инструкции по установке	RON	INSTRUCȚIUNI DE INSTALARE	CHI	安装说明
FRA	INSTRUCTIONS DE MONTAGE	SPA	INSTRUCCIONES DE INSTALACIÓN	POR	INSTRUÇÕES DE INSTALAÇÃO	SWE	INSTALLATIONSANVISNING	UKR	Інструкції з монтажу
SRP	UPUTSTVA ZA INSTALACIJU	AR	تعليمات التركيب						

								220-240V 50/60Hz	CxS 0.24m ² 0.027m ²	IP 66	IK 10
							9.2 kg 7.8 kg				

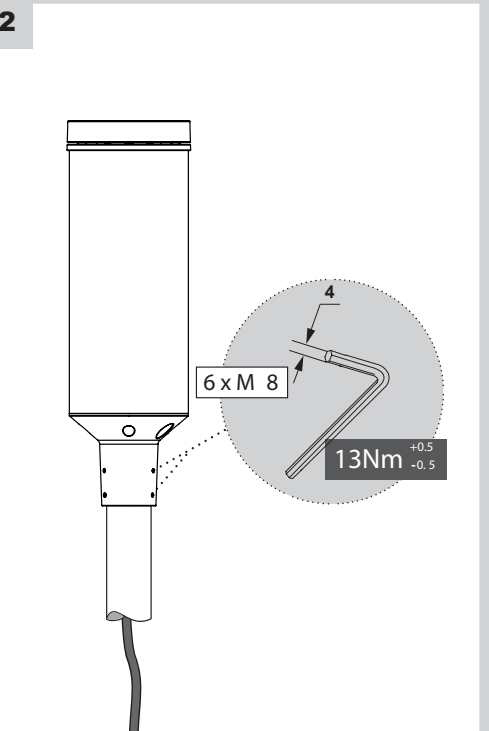
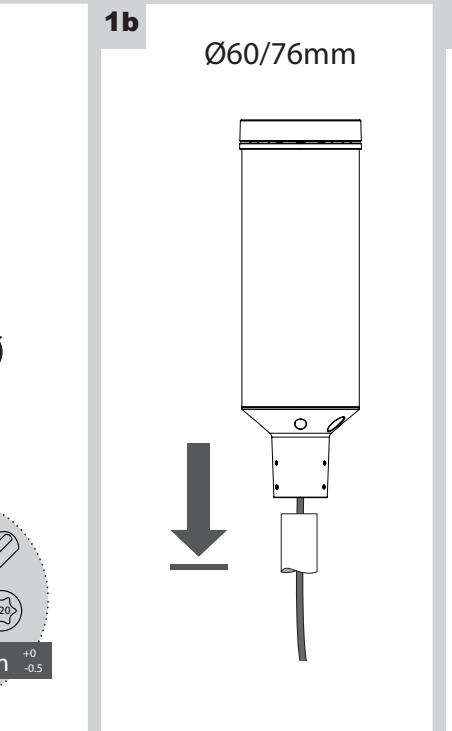
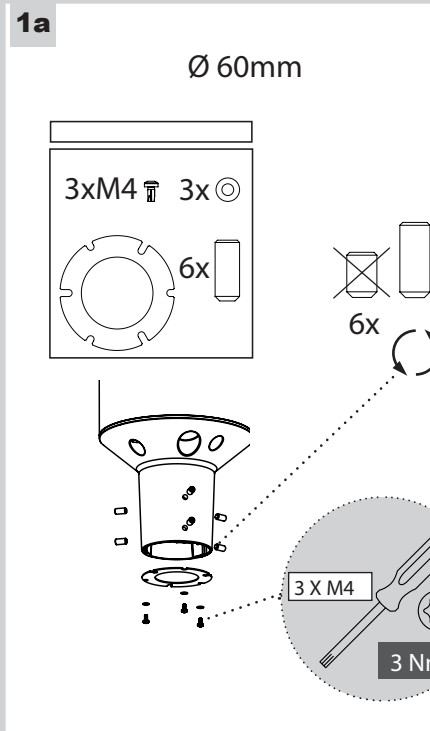
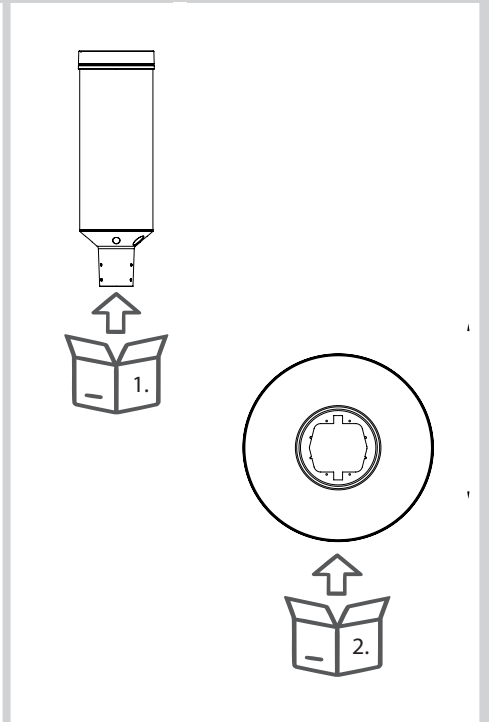
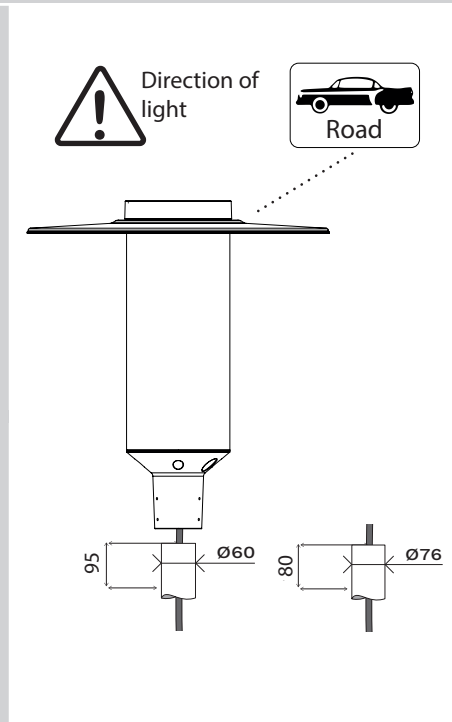
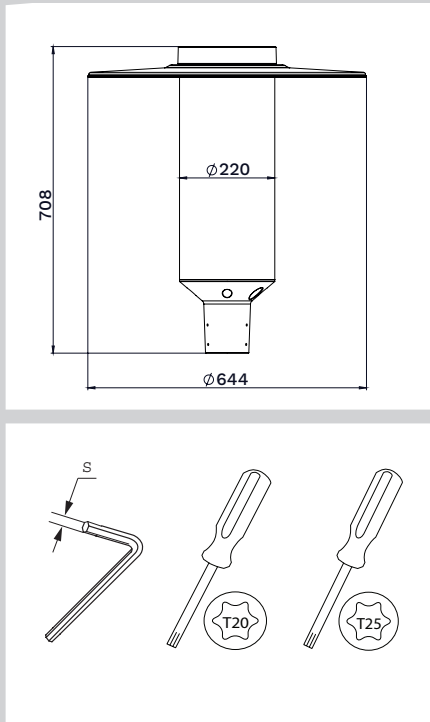

3a

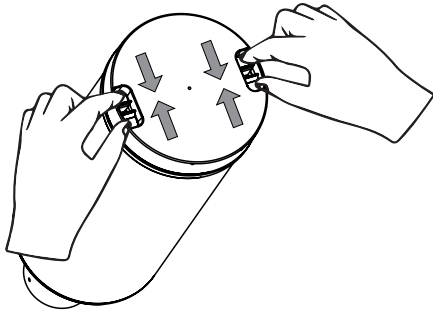
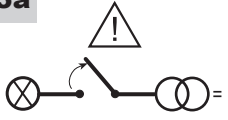

3b

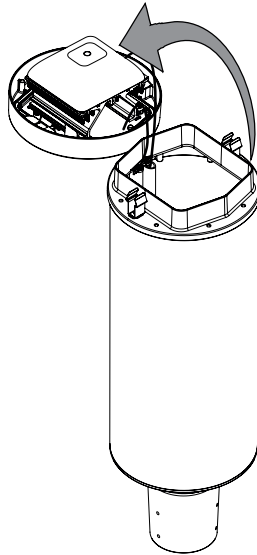

3c

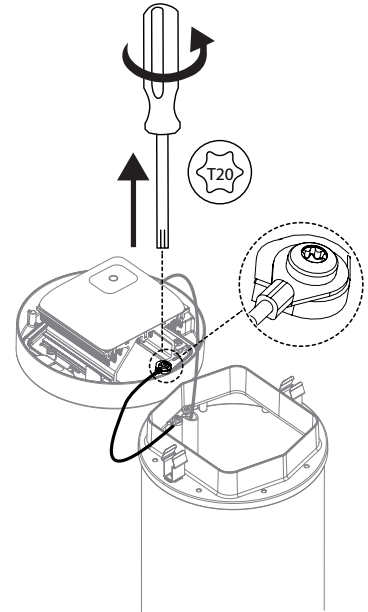

3d



NEMA + LVS

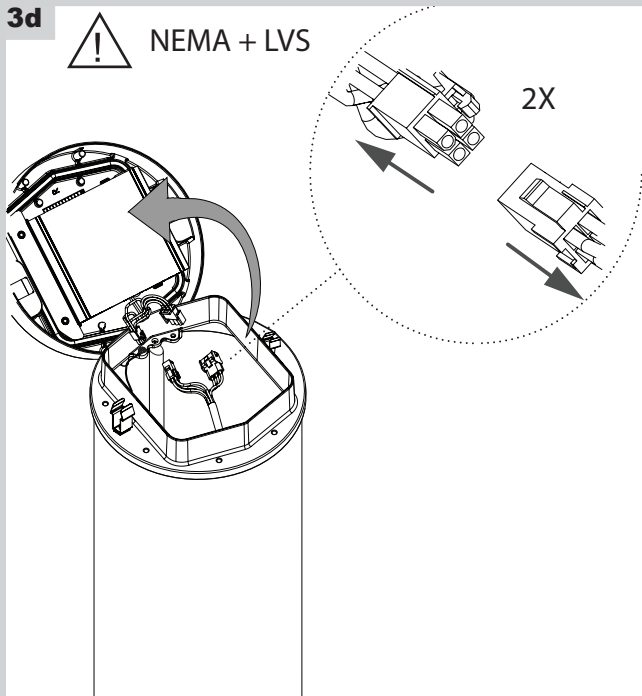

3e



4 x M5



4 Nm

+0
-0.5

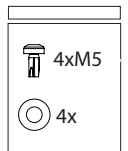
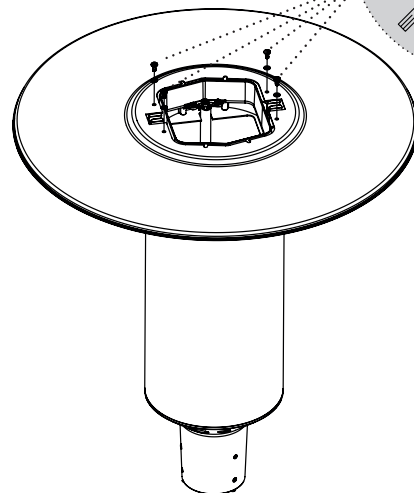

3f



1 x M4



3 Nm

+0
-0.5



NEMA + LVS

2x

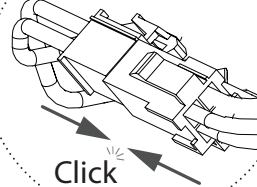

Click

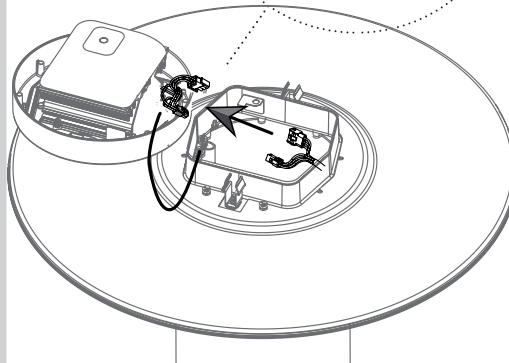

Click

Click

4a

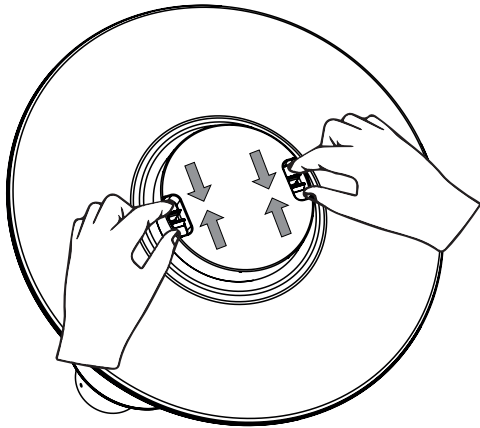
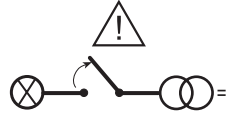

4b

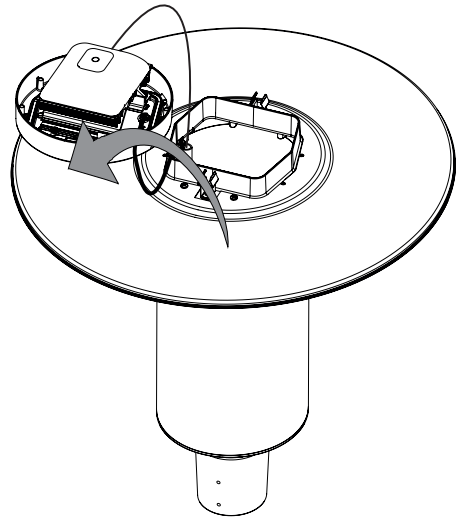

5a

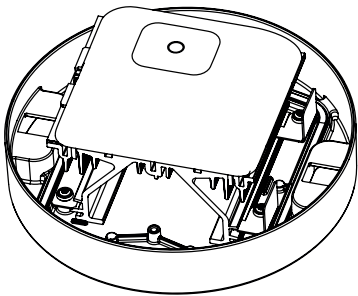

5b

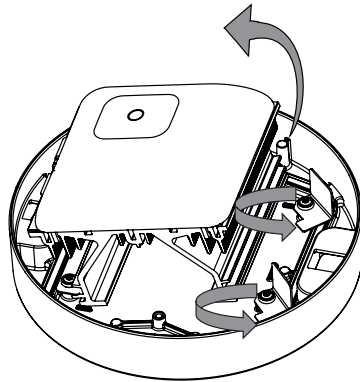

5c

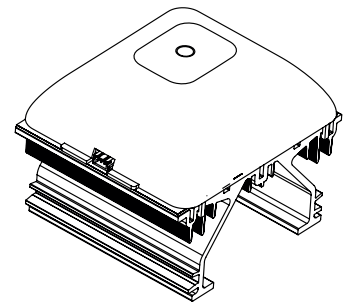

6

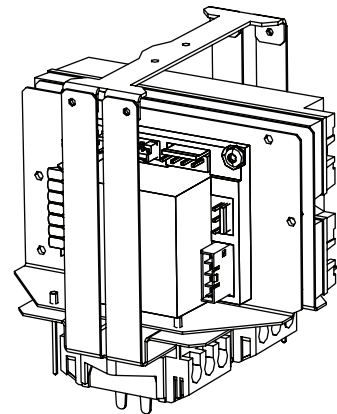
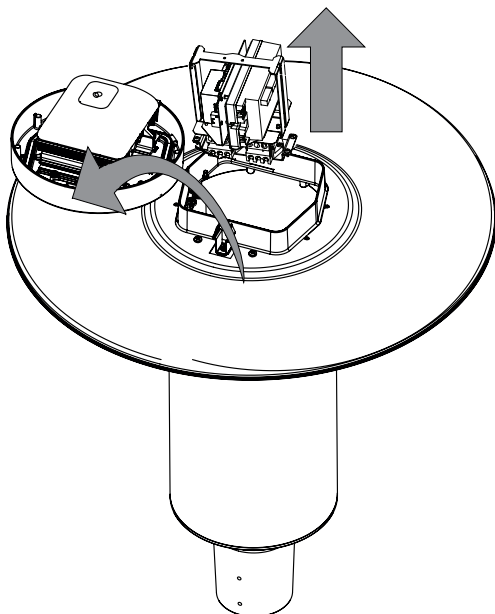

<p>ENG</p> <p>SAFETY INSTRUCTIONS The light source contained in this luminaire shall only be replaced by the manufacturer or his service agent or a similar qualified person. Always switch off the power prior to installation, maintenance or repair activities.</p> <p>RISK GROUP 2 - CAUTION! Hazardous optical radiation may be emitted from this product. Do not stare at the luminaire when operating as it may be harmful to the eyes. The luminaire should be positioned so that prolonged staring at the luminaire at a distance of less than 0.47m is not expected.</p> <p>This product contains a light source of an energy efficiency class G or higher.</p> <p>In case of PVC insulated mains cable, the installer MUST ensure that the WHOLE cable is protected against climatic conditions, especially UV rays and rain, by making sure that the cable is contained inside the luminaire and pole</p> <p>Y-connection: In case of damage to the wire, it has to be replaced only by the manufacturer, distributor or by an expert, to avoid risks.</p>	<p>ISTRUZIONI DI SICUREZZA La sorgente di luce contenuta in questo sistema di illuminazione dovrà essere sostituita solo dal produttore, dal suo agente di servizio o da una persona con qualifica simile.</p> <p>Staccare sempre il filo della corrente prima di iniziare operazioni di installazione, manutenzione o riparazione.</p> <p>GRUPPO DI RISCHIO 2 - ATTENZIONE! Questo prodotto può emettere radiazioni ottiche potenzialmente pericolose. Non fissare la sorgente accesa. Potrebbe essere dannoso per gli occhi. L'apparecchio dovrebbe essere posizionato in modo da non permettere di fissare a lungo l'apparecchio a una distanza inferiore di 0,47m.</p> <p>Questo prodotto contiene una sorgente luminosa di classe di intensità luminosa G o superiore.</p> <p>In caso di cavo di alimentazione isolato in PVC, l'installatore DEVE garantire che il cavo INTERO sia protetto dalle condizioni climatiche, in particolare dai raggi UV e dalla pioggia, assicurandosi che il cavo sia contenuto all'interno del corpo illuminante e del palo</p> <p>Collegamento Y: in caso di danneggiamento, il cavo deve essere sostituito esclusivamente dal costruttore, dal distributore o da un tecnico esperto per evitare rischi.</p>	<p>VEILIGHEIDSIINSTRUCTIES De lichtbron in deze armatuur dient uitsluitend door de fabrikant, diens onderhoudenverteenwoordiger of een persoon met vergelijkbare kwalificaties te worden vervangen.</p> <p>Schakel altijd de stroom uit voordat u aan installatie, onderhoud of reparaties begint.</p> <p>RISICOGROEP 2 - LET OP! Bij dit product kan eventueel gevaarlijke optische straling voorkomen. Staar niet in de brandende lamp. Dit kan schadelijk zijn voor de ogen. Het armatuur moet worden geplaatst zodat staren in het armatuur op een afstand kleiner dan 0,47meter niet verwacht wordt.</p> <p>Dit product bevat een lichtbron met energie-efficiëntieklasse G of hoger.</p> <p>In het geval van PVC-geïsoleerde voedingskabels MOET de installateur ervoor zorgen dat de GEHELE kabel wordt beschermd tegen klimaatomstandigheden, met name UV-stralen en regen, door ervoor te zorgen dat de kabel zich in het armatuur en de paal bevindt</p> <p>Y-verbinding: In geval van schade aan de draad dient deze te worden vervangen door de fabrikant, de distributeur of door een expert, om risico's te vermijden.</p>	<p>SIKKERHEDSIINSTRUKTIONER Lyskilden i dette armatur må kun udskiftes af producenten, af en vedligeholdelsesvirksomhed udeget af producenten eller af en tilsvarende kvalificeret virksomhed.</p> <p>Sluk altid for strømmen inden påbegyndelse af installation, vedligeholdelse eller reparation.</p> <p>Risikogruppe 2 - ADVARSEL! Produktet kan muligvis udsende farlig optisk stråling. Kig ikke direkte ind i armaturet under drift, det kan være skadeligt for øjnene. Armaturet skal placeres således så langvarig stirren ind i armaturet, på en afstand der er tættere end 0,47m, undgåes.</p> <p>Dette produkt indeholder en lyskilde af energieffektivitetsklasse G eller højere.</p> <p>I tilfælde af PVC-isoleret ledning SKAL elektrikererne sikre, at HELE kablet er beskyttet mod klimatiske forhold, dette gælder især UV-stråler og regn. Elektrikerens skal derfor sørge for, at kablet forbliver inde i armaturet og masten.</p> <p>Type Y montering: Hvis det eksterne kabel eller ledning på dette armatur er beskadiget, må det kun udskiftes af producenten eller af en servicepartner til producenten eller tilsvarende kvalificeret person, for at undgå skader.</p>	<p>SICHERHEITSHINWEISE Die Lichtquelle in dieser Leuchte darf nur vom Hersteller bzw. von dessen Kundendienst oder einer ähnlich qualifizierten Person ausgetauscht werden.</p> <p>Schalten Sie die Stromversorgung vor Installations-, Wartungs- und Reparaturarbeiten stets ab.</p> <p>Risikogruppe 2 - VORSICHT! Von diesem Produkt kann möglicherweise gefährliche optische Strahlung ausgehen. Es ist darauf zu achten, dass man im eingeschalteten Zustand der Leuchte nicht innerhalb einer Distanz von 0,47m direkt in die Leuchte schaut. Dies könnte schädlich für Ihre Augen sein.</p> <p>Dieses Produkt enthält eine Lichtquelle der Energieeffizienzklasse G oder höher.</p> <p>Bei Verwendung eines PVC-isolierten Netzkabels MUSS der Installateur sicherstellen, dass das GESAMTE Kabel vor klimatischen Bedingungen -insbesondere vor UV-Strahlen und Regen- geschützt ist, indem sichergestellt wird, dass das Kabel in der Leuchte und dem Mast verschlossen ist.</p> <p>Y-Verbindung: Falls die Leitung beschädigt ist, darf diese nur vom Hersteller, dem Händler oder einem Experten ersetzt werden, um Risiken zu vermeiden.</p>	<p>ISTRUKCIJA BEZBIECZEŃSTWA Źródło światła zamontowane w tej oprawie może być wymieniane wyłącznie przez producenta, pracownika serwisu lub inną wykwalifikowaną osobę.</p> <p>Przed rozpoczęciem instalacji, konserwacji lub naprawy należy bezwzględnie odłączyć zasilanie elektryczne.</p> <p>GRUPA RYZYKA 2 - OSTRZEŻENIE! Produkt może emitować niebezpieczne promieniowanie optyczne szkodliwe dla oczu. Nie należy patrzeć bezpośrednio na pracujące źródło światła. Oprawa powinna być tak zamontowana, aby jej długotrwała obserwacja była możliwa z odległości nie mniejszej niż 0,47m.</p> <p>Ten produkt zawiera źródło światła o klasie efektywności energetycznej G lub wyższej.</p> <p>W przypadku kabla sieciowego izolowanego PVC instalator MUSI upewnić się, że kabel CAŁY jest chroniony przed warunkami klimatycznymi, w szczególności przed promieniowaniem UV i deszczem, upewniając się, że kabel znajduje się wewnątrz oprawy i stupa.</p> <p>Połączenie Y: ze względów bezpieczeństwa uszkodzony przewód powinien zostać wymieniony wyłącznie przez producenta, dystrybutora lub wykwalifikowanego elektryka.</p>	<p>ИНСТРУКЦИЯ БЕЗОПАСНОСТИ Замену источника света для этого светильника должен выполнять только прозвводитель, сервисный агент производителя или специалист с аналогичной квалификацией.</p> <p>Перед проведением установки, сервисного обслуживания или ремонта всегда отключайте питание устройства.</p> <p>ГРУППА РИСКА 2 - ВНИМАНИЕ! Возможно опасное оптическое излучение от этого изделия. Не смотрите на источник света. Может быть вредно для глаз. Светильник должен быть расположен таким образом, чтобы было невозможно смотреть на него с расстояния менее 0,47м.</p> <p>Данное изделие содержит источник света класса энергоэффективности G или выше.</p> <p>В случае кабеля питания с ПВХ изоляцией, монтажник ДОЛЖЕН обеспечить защиту ВСЕГО кабеля от воздействия климатических условий, особенно от ультрафиолетовых лучей и дождя, убедившись, что кабель находится внутри светильника и опоры.</p> <p>Подключение Y: в случае повреждения кабеля его замена производится только производителем, дистрибутором или экспертом.</p>	<p>INSTRUCȚIUNI DE EXPLOATARE Sursa de lumină din acest corp de iluminat trebuie înlocuită numai de producător sau de reprezentantul său de service sau o persoană ce deține calificări similare.</p> <p>Opriti întotdeauna alimentarea electrică înainte de lucrările de instalare, întreținere sau reparații.</p> <p>GRUP DE RISC 2 - ATENȚIE! Este posibil ca acest produs să emită radiații optice periculoase. Nu priviți direct înspire lampa aflată în stare de funcționare. Acest lucru poate fi dăunător ochilor. Aparatul de iluminat trebuie să fie poziționat astfel încât să nu fie posibil, în mod normal, privirea directă înspire lampă, la o distanță mai mică de 0,47m.</p> <p>Acest produs conține o sursă de lumină din clasa de eficiență energetică G sau superioară.</p> <p>În cazul cablului de alimentare cu izolație din PVC, instalatorul TREBUIE să se asigure că TOT cablul este protejat împotriva condițiilor climatice, mai ales împotriva razelor UV și a ploii, asigurându-se că acest cablu este plasat în interiorul aparatului de iluminat și al stălpului.</p> <p>Conexiune Y: În caz de deteriorare a firului, acesta trebuie înlocuit numai de către producător, distribuitor sau un expert, pentru evitarea riscurilor.</p>	<p>INSTRUCTIONS DE SECURITE La source lumineuse contenue dans ce luminaire doit être uniquement remplacée par le fabricant, son agent de maintenance ou une autre personne disposant des qualifications appropriées.</p> <p>Mettez toujours l'appareil hors tension avant toute opération d'installation, d'entretien ou de réparation.</p> <p>RISQUE GROUPE 2 - ATTENTION ! Ce produit émet potentiellement des rayons dangereux pour la vue. Regardez directement la source lumineuse et de manière continue pourrait causer des lésions aux yeux. Le luminaire doit être installé de façon à ne pas pouvoir regarder la source lumineuse directement de manière continue à moins de 0,47m.</p> <p>Ce produit contient une source lumineuse de classe d'efficacité énergétique G ou supérieure.</p> <p>Dans le cas d'un câble secteur isolé en PVC, l'installateur DOIT s'assurer que le câble ENTIER est protégé contre les conditions climatiques, en particulier les rayons UV et la pluie, en s'assurant que le câble est contenu à l'intérieur du luminaire et du poteau</p> <p>Connexion Y : si le câble est endommagé, il ne peut être remplacé que par le fabricant, par le distributeur ou par un expert, afin d'éviter tout risque.</p>	<p>INSTRUCCIONES DE SEGURIDAD Solo el fabricante, un agente del servicio técnico o persona con cualificación similar puede sustituir la fuente de luz de este sistema de iluminación.</p> <p>Apague siempre el interruptor de alimentación antes de realizar tareas de instalación, mantenimiento o reparación.</p> <p>GRUPO DE RIESGO 2 - ¡PRECAUCIÓN! radiación óptica posiblemente peligrosa emitida por este producto. No mire a la lámpara en funcionamiento. Puede ser dañino para los ojos. El sistema de iluminación debe instalarse de modo que la mirada fija prolongada a la luminaria, a una distancia menor de 0,47m no se espere.</p> <p>Este producto contiene una fuente de luz de clase de eficiencia energética G o superior.</p> <p>En el caso de un cable aislado de PVC, el instalador DEBE asegurarse de que todo el cable esté protegido contra las condiciones climáticas, especialmente los rayos UV y la lluvia, asegurándose de que el cable esté dentro de la luminaria y el poste</p> <p>Conexión en Y: si el cable se daña, solo debe reemplazarlo el fabricante, un distribuidor o un experto para evitar riesgos.</p>	<p>INSTRUÇÕES DE SEGURANÇA A fonte de luz no interior deste candeeiro deve ser substituída apenas pelo fabricante, pelo seu técnico de assistência ou por uma pessoa com qualificação equivalente.</p> <p>Desligue sempre a alimentação antes de proceder a actividades de instalação, manutenção ou reparação.</p> <p>GRUPO DE RISCO 2 - ATENÇÃO! Possível risco ótico por radiação emitida a partir deste produto. Não olhar para a luz em funcionamento. Pode ser prejudicial para os olhos. A luminária deve ser posicionada de modo a que não seja expectável um olhar prolongado para a luminária em funcionamento a uma distância inferior a 0,47m.</p> <p>Este produto contém uma fonte de luz de classe de eficiência energética G ou superior.</p> <p>No caso de cabo de alimentação com isolamento em PVC, o instalador DEVE assegurar que TODO o cabo é protegido das condições climáticas, especialmente raios UV e chuva, certificando-se que o cabo está contido dentro da luminária e da coluna.</p> <p>Ligação Y: em caso de danos no fio, este tem de ser substituído apenas pelo fabricante, distribuidor ou por um técnico especializado, para evitar riscos.</p>	<p>SKÄRNETSIINSTRUKTIONER Ljuskällan som monteras i denna armatur får endast ersättas av en Schröder-anställd eller annan kvalificerad person.</p> <p>Stäng alltid av strömmen före installation, underhåll eller reparation.</p> <p>Risikgrupp 2 - VARNING! Eventuellt farlig optisk strålning från denna produkt. Stirra ej på driftlampan. Kan vara skadligt för ögonen. Armaturen bör placeras så att långvarigt stirrande in i armaturen på ett avstånd som är närmare än 0,47m ej är möjligt.</p> <p>Denna produkt innehåller en ljuskälla av energieffektivitetsklass G eller högre.</p> <p>Vid PVC-isolerad kabel måste installören se till att hela kabeln är skyddad mot klimatförhållanden, särskilt UV-strålar och regn, genom att se till att kabeln monteras inuti armaturen och stolpen</p> <p>Typ Y-anslutning: Om den externa kabeln eller ledningen på denna armatur är skadad, får den endast bytas ut av tillverkaren eller av en servicepartner till tillverkaren eller motsvarande kvalificerad person, för att undvika skador</p>	<p>BIZTONSÁGI ÚTMUTATÓ A lámpatestben található fényforrást kizárólag a gyártó, szervizképviseelő vagy hivatalos szakszervelet szakember cserélheti ki.</p> <p>A szerelés, karbantartás és javítás előtt minden esetben végezzen áramtalanítást.</p> <p>KOCKÁZATI CSOPORT 2 - VIGYÁZATI! A berendezés veszélyes optikai sugárzást bocsáthat ki! Ne nézzen bele a bekapcsolt lámpatestbe! Szemet károsító hatás léphet fel. A lámpatestet úgy ajánlott pozícionálni, hogy rálátás esetén a lámpatest ne legyen 0,47m-nél közelebb!</p> <p>Ez a termék G vagy magasabb energiahatékonysági osztályba tartozó fényforrást tartalmaz.</p> <p>PVC szigetelésű tápkábel esetén a telepítőnek biztosítania KELL, hogy a TELJES kábel védett legyen az éghajlati viszonyoktól, különösen az UV sugárzástól és az esőtől, ügyelve arra, hogy a kábel a lámpatest és az oszlop belsejében legyen.</p> <p>Y-csatlakozó: A sérült vezetékét kizárólag a gyártó, forgalmazó vagy szakember cserélheti ki a kockázatok elkerülése végett.</p>	<p>安全守則 该灯具内的光源仅可由施莱德员工、指定代理商或具备类似资质的人员进行更换。</p> <p>在安装、维护和维修灯具之前必须首先切断电源。</p> <p>风险群体 2 - 注意! 有害的光学射线有可能从产品中发出。不要直视正在工作的光源。有可能对眼睛产生危害。灯具应当选择合理位置安装，尽可能避免长时间在0.47米以内凝视。</p> <p>本产品包含一个能源效率等级为 I 或更高的光源。</p> <p>Y类附件： 如果灯具外部电缆被破坏，电缆必须被制造商或服务代理商或者有资质的人员及时更换从而避免伤害。</p>	<p>إجراءات السلامة: في حالة الحاجة لتغيير مصدر الضوء، يتم ذلك من خلال الشركة المصنعة أو الوكيل المخول لعمل ذلك أو شخص موهل لذلك. دائما أفضل الدائرة الكهربائية قبل تركيب أو صيانة الجهاز. تحذير: هذا المنتج مصنف ضمن مجموعة الخطر 2 خطر. إنبعاث اشعاع ضوئي، لا تنظر مباشرة إلى الجهاز و هو مضاء لأن ذلك يؤدي لتهين العين. الجهاز يجب ان يركب بشكل يضمن ان التحديق بمصدر الضوء من مسافة اقل من 0.47 م غير متوقعة.</p> <p>أو أعلى G يحتوي هذا المنتج على مصدر ضوء من فئة كفاءة الطاقة يجب على الشخص الذي يوصل الجهاز بالدائرة الكهربائية التأكد من أن محمي من التأثيرات المناخية وخاصة الأشعة فوق البنفسجية والمطر من خلال التأكد ان الكابل محمي بداخل العمود والجهاز</p> <p>في حالة الحاجة لتغيير الامداد الداخلي، يتم ذلك من خلال الشركة المصنعة أو الوكيل المخول لعمل ذلك أو شخص موهل لذلك. دائما أفضل الدائرة الكهربائية قبل تركيب أو صيانة الجهاز.</p>	<p>інструкція безпеки Джерело світла, що міститься у цьому світильнику, повинні замінювати лише виробник, його сервісний агент або кваліфікована особа.</p> <p>Завжди вимикайте живлення перед встановленням, доглядом або ремонтом.</p> <p>ГРУПА РИЗИКУ 2 - УВАГА! Можливість небезпечного оптичного випромінювання від цього продукту. Уникайте прямого погляду на вмищене джерело світла. Може бути шкідливо для очей. Светильник має бути розташований так, щоб уникнути його тривалого споглядання з відстані ближче, ніж 0,47м.</p> <p>Цей продукт містить джерело світла класу енергоефективності G або вище.</p> <p>У випадку кабелю живлення із ПВХ ізоляцією, монтажник ПОВИНЕН забезпечити захист ВСЬОГО кабелю від впливу кліматичних умов, особливо від ультрафіолетових променів та дощу, переконавшись, що кабель знаходиться всередині світильника та опоры</p> <p>Y-з'єднання: у разі пошкодження дроту його має замінити лише виробник, дистрибутор чи експерт, щоб запобігти ризикам.</p>	<p>UPUTSTVA Izvor svetla u ovom rasvetnom telu može da zameni samo proizvođač, njegov servisni agent ili na sličan način kvalifikovana osoba.</p> <p>Uvek isključite napajanje pre instalacije, održavanja ili popravke.</p> <p>GRUPA RIZIKA 2 - PAŽNJA! Proizvod može emitovati štetno optičko zračenje. Izbjegavati vizuelni kontakt sa svetlosnim izvorom dok je u radu. Moguće oštećenje vida. Svetiljku treba pozicionirati tako da se ne očekuje duži vizuelni kontakt sa izvorom sa razdaljinom manje od 0,47m.</p> <p>Ovaj proizvod sadrži izvor svetlosti klase energetske efikasnosti G ili više.</p> <p>U slučaju napojnog kabla sa PVC izolacijom, izvođač MORA obezbediti zaštitu CELOG kabla od klimatskih uslova, posebno UV zračenja i kiše, tako što ce osigurati da se kabal nalazi unutar svetiljke i stupa.</p> <p>Y-veza: U slučaju oštećenja žice zamen mora da obavij isključivo proizvođač, distributer ili stručnjak kako bi se izbegao rizik.</p>
---	--	--	--	---	--	---	--	---	---	---	--	---	--	--	--	---

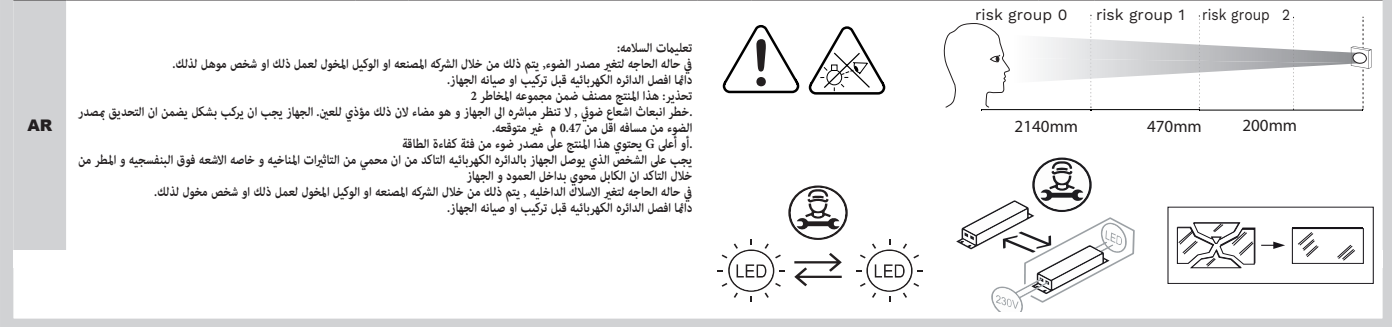

Copyright © Schréder S.A. - 2022 - Executive Publisher: Stéphane Halleux - Schréder International Services S.A. - B-4000 Liège, Rue de Mons 3 (Belgium) - The information, descriptions and illustrations herein are only of an indicative nature and subject to changes without notice.